

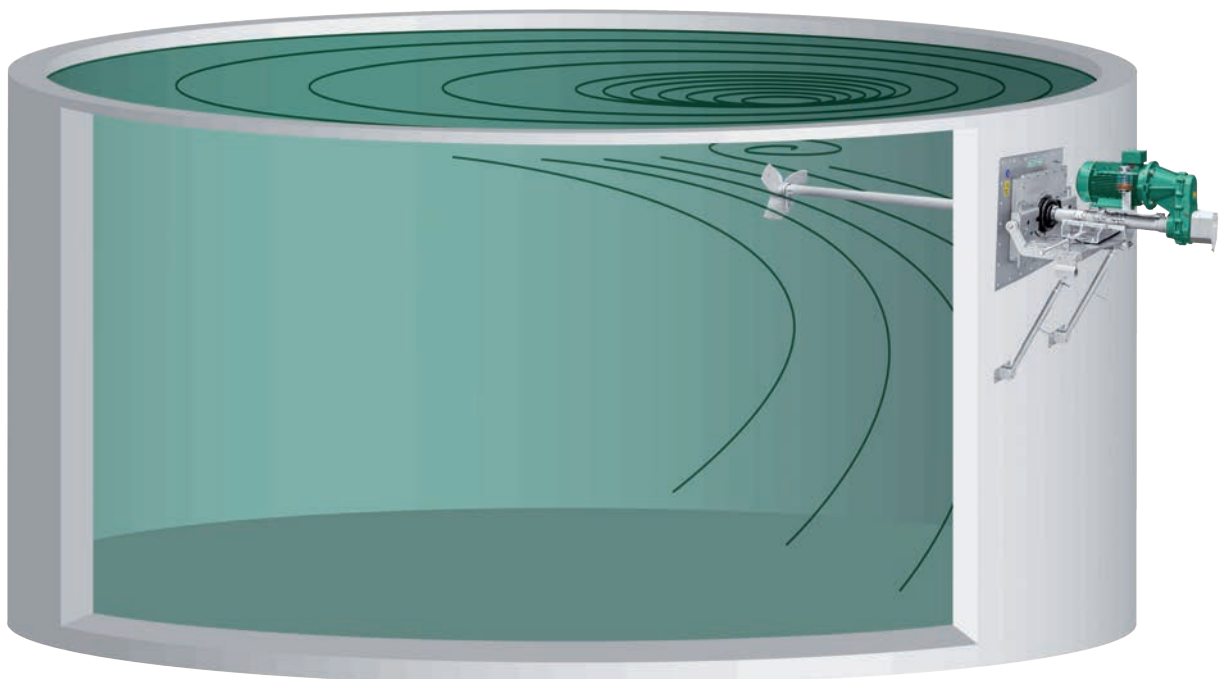

# BIOGAS AGITATORS

Our range of products

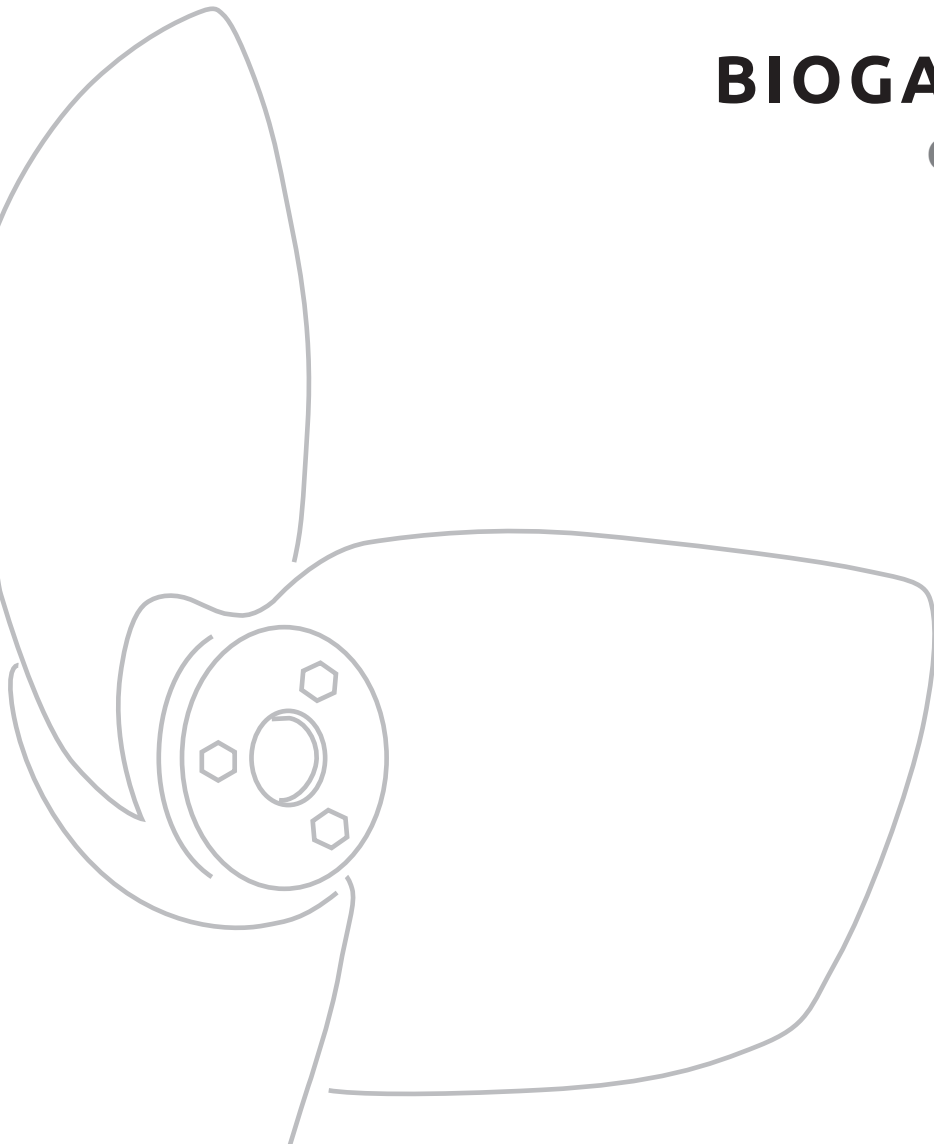

# Long-axis agitator GIANTMIX FR 30°



For concrete and steel tanks - mounting through the wall

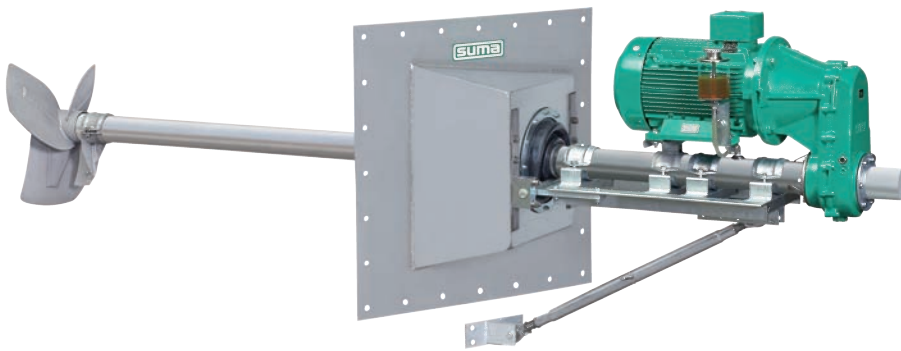

## FR 1 - 5 (200 | 275 | 400 rpm)

- Tube Ø 101.6 mm in ss304 or ss316
- Tube wall thickness 4.0 or 5.7 mm
- Tube length 3 or 4 m
- Propeller Ø 660 - 850 mm in ss304, ss316 or hardened steel
- Ex-motor with 7.5 kW (200 rpm) | 11 kW / 15 kW (275 rpm - IE3) | 15 / 18.5 kW (400 rpm - IE3) for ex-zone 2
- Power 13.5 kW for ex-zone 1
- PTC thermistors 160°C as overheat protection
- Low noise spur gear (i=5.31 or 3.69)
- Bearing housing with mechanical seal SiC/SiC independent of rotation and two tapered roller bearings to absorb the axial forces
- Sealing plates in ss304 or ss316 in three sizes
- Sealing membrane or rubber compression seal in EPDM 60
- Oil equalizing container for monitoring the tightness of the mechanical seal
- Installation depth up to 1.5 m beneath substrate level, deeper immersion depths on request
- Vertical inclination with upper link or optional  $\pm 25^\circ$  with pinion rack
- Option: rain protection hood in ss304
- Option: tractor-driven configuration through PTO-connection
- Giantmix FR 30° HY: without motor and with PTO connection



# Long-axis agitator GIANTMIX FR SP



For concrete and steel tanks - mounting through the wall

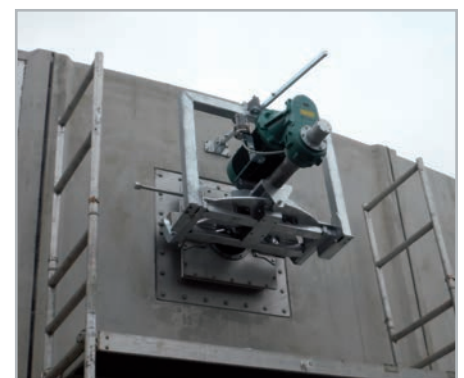
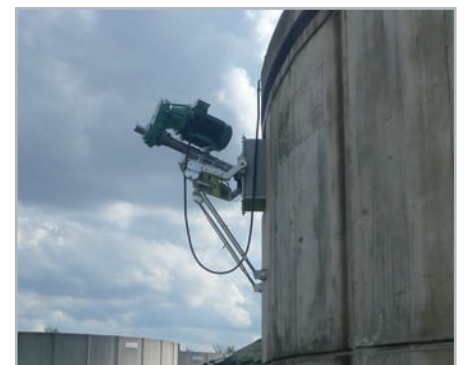
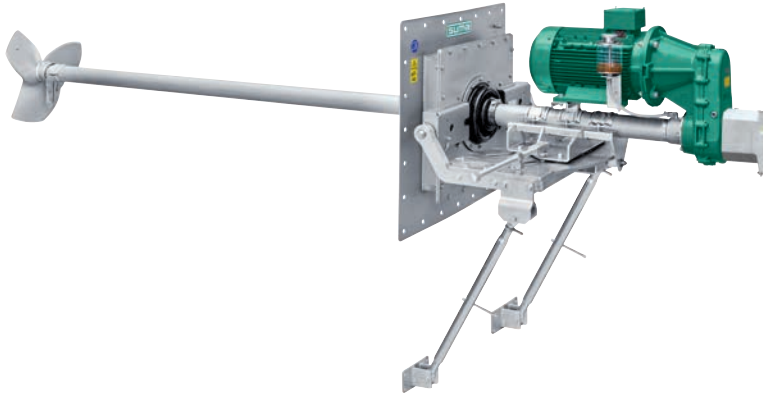

## FR 1 - 5 (200 | 275 | 400 rpm)

- Tube Ø 101.6 mm in ss304 or ss316
- Tube wall thickness 4.0 or 5.7 mm
- Tube length 3 or 4 m
- Propeller Ø 660 - 850 mm in ss304, ss316 or hardened steel
- Ex-motor with 7.5 kW (200 rpm) | 11 kW / 15 kW (275 rpm - IE3) | 15 / 18.5 kW (400 rpm - IE3) for ex-zone 2
- Power 13.5 kW for ex-zone 1
- PTC thermistors 160°C as overheat protection
- Low noise spur gear ( $i=5.31$  or  $3.69$ )
- Bearing housing with mechanical seal SiC/SiC independent of rotation and two tapered roller bearings to absorb the axial forces
- Sealing plates in ss304 or ss316 in three sizes
- Sealing membrane in EPDM 60
- Oil equalizing container for monitoring the tightness of the mechanical seal
- Installation depth up to 8 m beneath substrate level through SUMA special sealing system. Deeper immersion depths on request
- Horizontal adjustment  $\pm 25^\circ$  with hand spindle
- Vertical inclination with upper link or optional  $\pm 30^\circ$  with pinion rack or hydraulic cylinder
- Option: rain protection hood in ss304
- Option: tractor-driven configuration with PTO-connection
- Giantmix FR SP HY: without motor and with PTO connection

# Long-axis agitator GIANTMIX FR



For steel tanks and steel tower - mounting through the wall



## FR 1 - 5 (200 | 275 | 400 rpm)

- Tube Ø 101.6 mm in ss304 or ss316
- Tube wall thickness 4.0 or 5.7 mm
- Tube length 3 or 4 m
- Propeller Ø 660 - 850 mm in ss304, ss316 or hardened steel
- Ex-motor with 7.5 kW (200 rpm) | 11 kW / 15 kW (275 rpm - IE3) | 15 / 18.5 kW (400 rpm - IE3) for ex-zone 2
- Power 13.5 kW for ex-zone 1
- PTC thermistors 160°C as overheat protection
- Low noise spur gear (i=5.31 or 3.69)
- Bearing housing with mechanical seal SiC/SiC independent of rotation and two tapered roller bearings to absorb the axial forces
- Sealing plates in ss304 or ss316 in three sizes
- Sealing membrane or rubber compression seal in EPDM 60
- Oil equalizing container for monitoring the tightness of the mechanical seal
- Installation depth up to 3 m beneath substrate level through SUMA special sealing membranes. Deeper immersion depths on request
- Vertical inclination through upper link or optional + 5° / - 25° through pinion rack
- Option: rain protection hood in ss304



# Long-axis agitator GIANTMIX FR stationary



For concrete and steel tanks - mounting through the wall

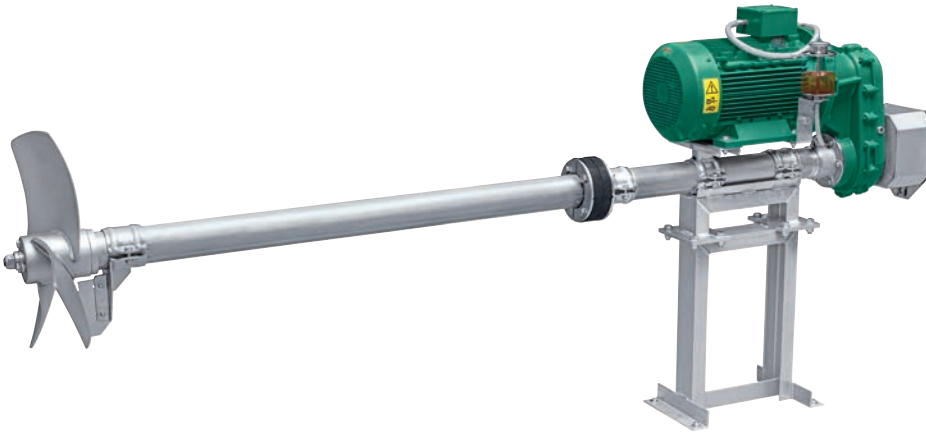

## FR 3 - 5 (400 rpm)

- Tube Ø 101.6 mm in ss304 or ss316
- Tube wall thickness 4.0 or 5.7 mm
- Tube length 2.5 or 3 m
- Propeller Ø 580 - 660 mm in ss304, ss316 or hardened steel
- Ex-motor with 11 kW | 15 kW | 18.5 kW (400 rpm - IE3) for ex-zone 2
- PTC thermistors 160°C as overheat protection
- Low noise spur gear (i=3.69)
- Bearing housing with mechanical seal SiC/SiC independent of rotation and two tapered roller bearings to absorb the axial forces
- Installation console to set in concrete
- Oil equalizing container for monitoring the tightness of the mechanical seal
- Installation depth up to 6 m beneath substrate level, deeper immersion depths on request
- Vertical inclination through upper link or optional  $\pm 25^\circ$  through pinion rack
- Option: rubber compression seal Ø 200 mm in EPDM60
- Option: rain protection hood in ss304
- Option: tractor-driven configuration through PTO-connection
- Giantmix Z3 HY: without motor and with PTO connection

# Long-axis agitator GIANTMIX FR light



## For small concrete tanks

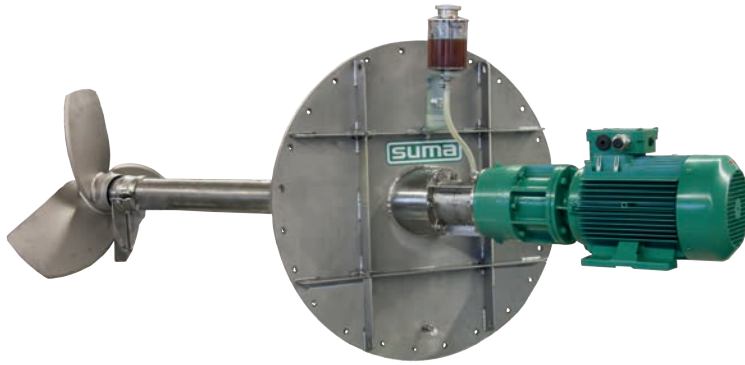

### FR light (330 rpm)

- Tube Ø 101,6 x 5,74 mm in ss304, ss316 on request
- Tube length 1,0 m / 1,5 m
- Propeller Ø 520 - 700 mm in ss304, ss316 or hardened steel
- Ex-motor with 4 kW (180/250 rpm) / 7,5 kW (280/380 rpm)
- PTC thermistors 160°C as overheat protection
- Low noise spur gear (i=5,31 bzw. 3,69)
- Mechanical seal SiC/SiC and two tapered roller bearings to absorb the axial forces
- Sealing plate DN 700 (Ø860 mm), other dimensions on request
- Sealing plate with other inclinations on request
- Oil equalizing container for monitoring the tightness of the mechanical seal
- Installation depth up to 6 m beneath substrate level through SUMA special sealing system. Deeper immersion depths on request
  
- Option: rain protection hood in ss304
- Option: tractor-driven configuration through PTO-connection



POM protective sleeve to minimize abrasion. the protective sleeve is suitable for many long axis agitators or submersible motors of SUMA. It can be retrofit on installed agitators. It is mountable with just few work steps. The installation instruction is within the delivery scope.

# Long-axis agitator GIANTMIX FT



For concrete tanks - mounting through the wall or ceiling



## FT 1 - 6 (200 | 275 | 400 rpm)

- Tube Ø 159 mm in ss304 or ss316
- Tube wall thickness 5.0 mm
- Tube length 4 / 5 / 5.5 / 6 m
- Propeller Ø 660 - 880 mm in ss304, ss316 or hardened steel
- Ex-motor with 7.5 kW (200 rpm) | 11 / 15 / 18.5 kW (275 rpm - IE3) | 15 / 18.5 / 22 kW (400 rpm - IE3) - for ex-zone 2
- PTC thermistors 160°C as overheat protection
- Low noise spur gear (i=5.31 or 3.69)
- Bearing housing with mechanical seal SiC/SiC independent of rotation and two tapered roller bearings to absorb the axial forces
- Sealing plates in ss304 or ss316 in two sizes
- Sealing membrane in EPDM 60
- Oil equalizing container for monitoring the tightness of the mechanical seal
- Installation depth up to 8 m beneath substrate level through SUMA special sealing system. Deeper immersion depths on request
- Horizontal adjustment  $\pm 30^\circ$  through hand spindle
- Vertical inclination  $\pm 30^\circ$  through hydraulic cylinder
- Option: cylinder holder upwards with two hydraulic cylinders
- Option: rain protection hood in ss304
- Option: tractor-driven configuration through PTO-connection
- Giantmix FT HY: without motor and with PTO connection



HY

# Long-axis agitator GIANTMIX AMX



For mounting through the tank wall or roof

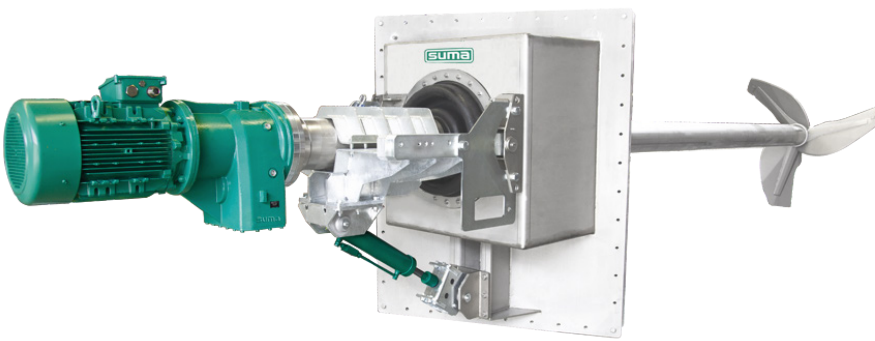

## GIANTMIX AMX

- ATEX-motor with 15 | 18.5 | 22 kW (80 rpm)
- Low noise spur gear (i=18)
- Bearing flange with mechanical seal SiC/SiC
- Tube in ss316: 4 | 5 | 6 m length
- Propeller-Ø 1,600 mm in ss304, optional ss316
- Sealing membrane in EPDM 60
- Installation depth up to 6 m below substrate level
- Sealing plate 1,430 x 1,730 mm optional right or left 25° preset, other ranges on request
- Vertical inclination through hydraulic cylinder + 5° / - 30°
- PTC 150°C - thermistors (overheat protection)
- Oil equalizing container for monitoring the tightness
- Damping system with special rubber on cylinder wall bracket and in hinged brackets
- POM protection to minimize abrasion
- AMX top mounting possible





# Long-axis agitator GIANTMIX AMT



## For concrete tanks - mounting through the wall

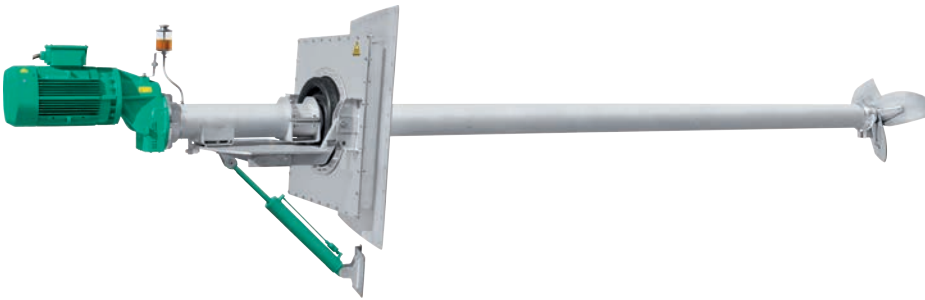

### AMT 6 - 7 (270 rpm)

- Tube Ø 220 mm in ss316
- Tube wall thickness 8.0 mm
- Tube length 5 / 6 / 6.5 m
- Propeller Ø 780 - 850 mm in hardened steel, ss304 or ss316
- Ex-motor with 22 / 28 kW - for ex-zone 2
- PTC thermistors 160°C as overheat protection
- Low noise spur gear (i=5.37)
- Bearing housing with mechanical seal SiC/SiC independent of rotation and two tapered roller bearing to absorb the axial forces
- 15°-sealing plates in ss304 or ss316
- Sealing membranes in EPDM 60
- Oil equalizing container for monitoring the tightness
- Installation depth up to 6 m beneath substrate level, deeper immersion depths on request
- Horizontal adjustment  $\pm 25^\circ$
- Vertical inclination  $\pm 30^\circ$  through hydraulic cylinder
- Giantmix AMT HY: without motor and with PTO connection

### AMT 3 / 5 (135 rpm)

- Tube length 4 / 5 m
- Propeller Ø 1.050 - 1.200 mm in hardened steel, ss304 or ss3016
- Ex-motor with 11 / 18.5 kW - for ex-zone 2
- Horizontal adjustment  $\pm 20^\circ$
- SUMA-damping system on cylinder wall bracket and within the swivel arms
- Reinforced sealing plates
- Other datas like AMT 6 - 7

# Electric-agitators GIANTMIX BG2



## For lagoons and containers

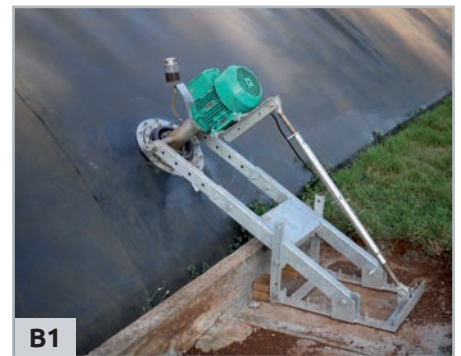

### Giantmix BG2

- Tube Ø 101.6 x 5.7 mm stainless steel ss304, optional ss316
- Tube length 4.0 / 5.0 m
- Propeller Ø 560 / 750 mm
- Ex-motor 10 kW | 50 Hz | (280 or 380 rpm) for ex-zone 2
- PTC thermistors 160°C as overheat protection
- Stub shaft with intermediate bearings and both sided connection
- Planetary gear (i=5.25 or 3.83)
- Bearing housing with mechanical seal SiC/SiC independent of rotation and two tapered roller bearings to absorb the axial forces
- Oil equalizing container for monitoring the tightness of the mechanical seal
- Foil clamp unit (for propeller sizes max. Ø 560 mm)

# Submersible motor OPTIMIX



For biogas tanks and lagoons

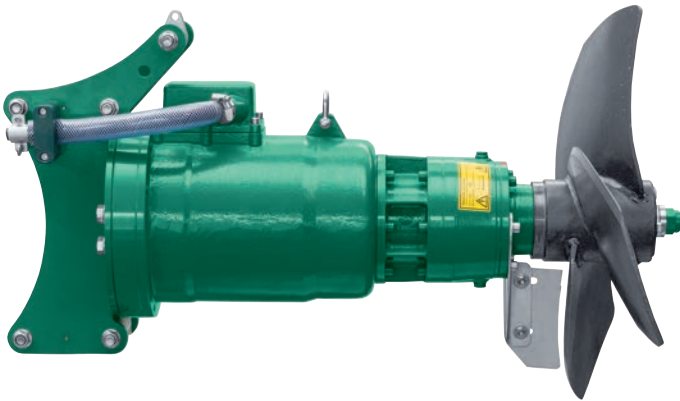

## Optimix 2G / 3G

2G 30-710:	3 kW	710 rpm	LD 380
2G 40-180:	4 kW	180 rpm	HD+ 700
2G 40-250:	4 kW	250 rpm	HD+ 620
2G 40-950:	4 kW	950 rpm	LD 310
2G 90-75:	9 kW	75 rpm	LT 1400
2G 90-280:	9 kW	280 rpm	HD+ 800
2G 90-380:	9 kW	380 rpm	HD+ 580
2G 150-275:	15 kW	275 rpm	HD+ 850
2G 150-380:	15 kW	380 rpm	HD+ 660
3G 250-270:	25 kW	270 rpm	HD+ 900

- Propeller in ss304, optional in hardened steel or ss316
- Bearing flange with mechanical seal SiC/SiC and two tapered roller bearings to absorb the axial forces
- Three separated oil circuits for motor, gear and bearing flange
- Longlife oil within the gear and bearing flange
- PTC thermistors 130°C as overheat protection
- 4-rollers guidance for 80 x 80 / 100 x 100 / 120 x 120 / 150 x 150 mm masts
- Galvanical isolated to the guide mast and to the ss316 rope
- Delivery incl. microbe resistant connection cable
- Option: star-delta switch (max. 15 kW) or soft start with timer

# Submersible motor OPTIMIX 2A



For aggressive media and low pH-values

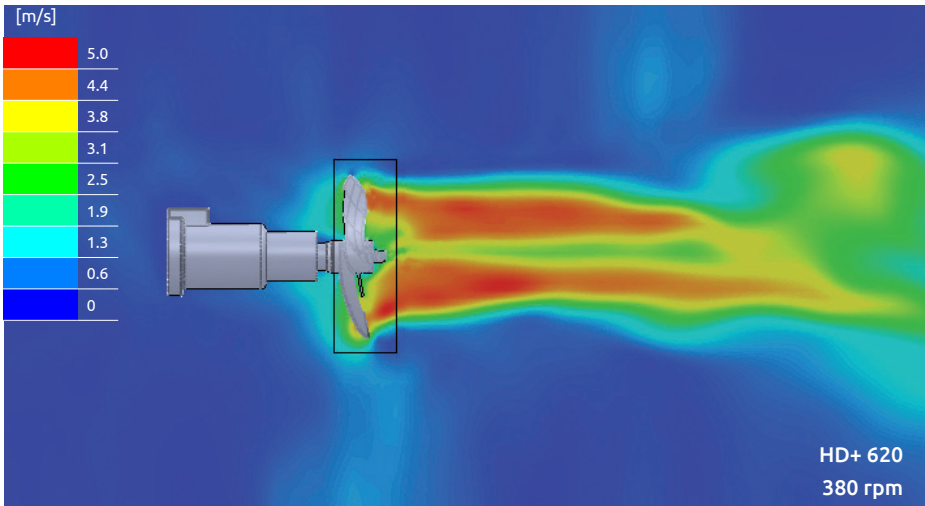

## OPTIMIX 2A / 3A

2A 30-710:	3 kW	710 rpm	LD 380
2A 40-180:	4 kW	180 rpm	HD+ 700
2A 40-250:	4 kW	250 rpm	HD+ 620
2A 40-950:	4 kW	950 rpm	LD 310
2A 90-280:	9 kW	280 rpm	HD+ 750
2A 90-380:	9 kW	380 rpm	HD+ 580
2A 135-280:	13.5 kW	280 rpm	HD+ 800
2A 135-380:	13.5 kW	380 rpm	HD+ 620
3A 250-270:	25 kW	270 rpm	HD+ 900

- Propeller in ss304, optional ss316
- Bearing flange with mechanical seal SiC/SiC and two tapered roller bearings to absorb the axial forces
- Three separated oil circuits for motor, gear and bearing flange
- Longlife oil within the gear and bearing flange
- PTC thermistors 130°C as overheat protection
- 4-rollers guidance for 80 x 80 to 150 x 150 mm masts
- Galvanically isolated to the guide mast and ss316 rope
- Delivery incl. microbe resistant connection cable
- Optimix 2A 135-280 and Optimix 2A 135-380 for Ex-Zone 1
- Optimix 2A/3A completely in ss304: up to min-pH-value 5.5
- Optimix 2A/3A completely in ss316: up to min-pH-value 4.5
- Option: star-delta switch (max. 15 kW) or soft start with timer

## Mounting through the tank wall

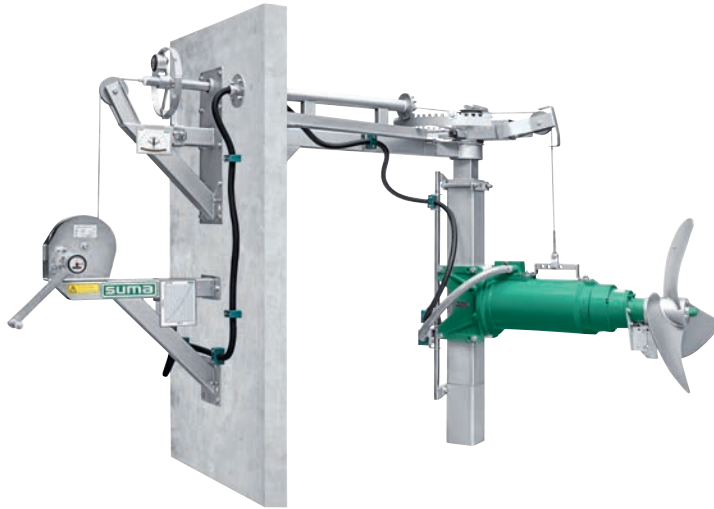

### Mast gastight wall lead through (MGD)

- Guide mast: 100 x 100 / 120 x 120 / 150 x 150 mm in ss316
- For tank heights up to 12 m
- Heavy version necessary for mast heights 10 - 16 m
- For concrete tanks 120 cm distance to the wall
- For steel tanks 70 cm distance to the wall
- Innovative gastight rope lead through
- Cable guidance behind the mast with cable clips and strain relief
- Base frame for doweling
- Horizontal adjustment of the Optimix up to 210° from the outside through hand wheel and slewing ring
- Height adjustment through ss304-rope winch (max. strain relief 900 kg) and ss316-rope Ø 8 mm
- Option: Height indication to determine the exact height of the agitator within the tank
- Option: angle display to determine the exact horizontal angle of the agitator within the tank

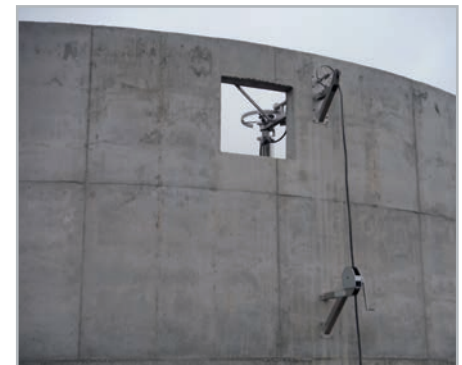

# Gastight ceiling lead through (GDD)



## Mounting through the tank ceiling

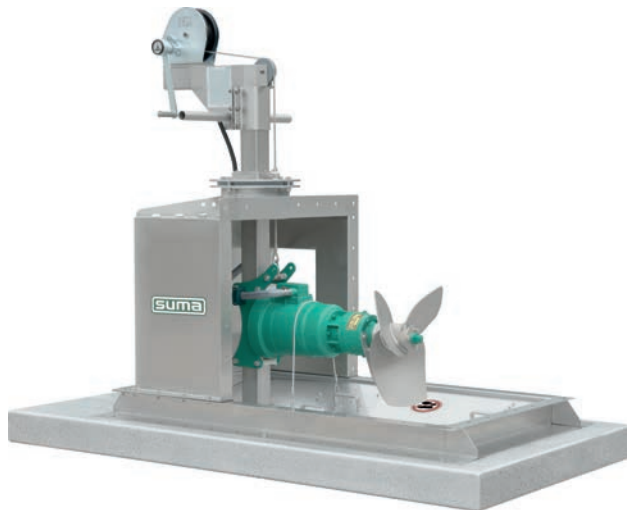

### Gastight ceiling lead through (GDD)

- For tank heights up to 14 m and concrete ceiling
- Heavy version necessary for mast heights 10 - 14 m
- Guide mast: 100 x 100 / 120 x 120 / 150 x 150 mm in ss316
- Innovative gastight rope lead through
- Height adjustment through ss304 rope winch (max. strain relief 900 kg) and ss316 rope  $\varnothing$  8 mm
- Cable guidance behind the mast with cable clips and strain relief
- Horizontal adjustment 360°
- Height indication to determine the exact height of the agitator within the tank
- Inspection glass with rinsing unit
- Servicebox:
  - Sealing plate 1,870 x 1,070 x 3 mm in ss316
- Maintenance unit (Option):
  - Base frame 2,030 x 1,230 x 3 mm in ss316
  - Maintenance flaps to close the tank while doing service and maintenance work



# Suspension mounting frame (EV)



## Suspension mounting frame for open tanks and end storages



### Suspension mounting frame EV3 / EV4 / EV5

- All OPTIMIX-series useable - 2G / 2A / 3G / 3A
- Possible installation in tanks up to 12 m depth
- EV3: Doweling of the mast holder on the inside tank wall
- EV4: Doweling of the mast holder onto the outside tank ceiling
- EV5: Doweling the mast holder on the inside tank wall and the gallow holder on the outside tank wall
- EV5 at smell emission
- +/- 60° horizontal adjustment
- ss304-guide mast 100 x 100 / 120 x 120 / 150 x 150 mm
- Height adjustment through galvanized rope winch and ss316 rope Ø 8 mm
- Cable guidance on the rope (EV3 / EV4)
- SUMA-cable guidance and strain relief behind the mast (EV5, optional EV3)
- Gallow, base frame and wall support bracket in ss304
- Option: Height indication to determine the exact height of the agitator within the tank
- Option: rope winch in ss304



### **CONTACT**

SUMA Rührtechnik GmbH  
Martinszeller Str. 21  
DE - 87477 Sulzberg  
Phone: +49 8376 92 131 -0  
Fax: +49 8376 92 131 -19  
E-Mail: [info@suma.de](mailto:info@suma.de)  
[www.suma.de/en](http://www.suma.de/en)

### **YOUR LOCAL PARTNER**